

Packaging the Pill

Doctors have long been plagued with patients who failed to take their medicine. Only recently have packages for prescription drugs been designed to help patients remember. The “Dialpak”,¹ issued in 1963 with the oral contraceptive Ortho-Novum, appears to have been the first “compliance package” for a prescription drug – one that is intended to help the patient comply with the doctor’s orders. This distinctive package and the social notoriety of the birth control pill (“the Pill”) have made it the most readily recognised prescription drug on the market. Since G. D. Searle & Co. introduced the first oral contraceptive in 1960, the Pill’s package has become familiar to both men and women from its depiction on the covers of news-stand magazines and popular books,² although a single tablet of an oral contraceptive, if separated from its container, could be recognised only by an experienced pharmacist.

Not surprisingly, the revolution in drug packaging heralded by the Dialpak has been overlooked in the midst of other revolutions associated with the Pill. Yet design changes in the package had a significant pharmacological effect – the number of hormone-containing pills in each prescription was increased. This unexpected result from what seems a rather inconsequential accessory to a complex medical technology will be used to illustrate the important part that consumer concerns, product presentation and patent issues play in establishing pharmaceutical regimens.

Historians who have studied the oral contraceptive have concentrated on its scientific development and progress through drug approval legislation, the public furore over its side-effects, and its role in the sexual and social revolutions of the 1960s and 1970s. Little has been said about the Pill’s manufacture and production, and its package has gone unnoticed in histories of the Pill; in fact, little has been written on the history of drug packaging. The cultural context that historians have provided for the Pill has been that of the society at large or women as a group. Recently, Elizabeth Watkins has shown how the Pill changed women’s relationships with their physicians. Lara Marks’ studies of the clinical trials of the oral contraceptive have examined the problem of patient compliance with research protocols.³ The history of the compliance packaging for the Pill provides another example of the way issues unrelated to the medical science of chemical contraception affected women’s daily experience with the Pill and also contributed to medical opinion of women in the 1960s.

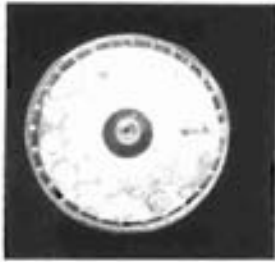

Figure 1. David P. Wagner's pill dispenser prototype is made of three round plastic plates held by a snap fastener. The bottom plate has the day-of-the-week pattern, the middle plate holds twenty wooden "pills" in a pattern that rotates to match the day pill-taking begins, a single hole in the top plate is moved over the pill to dispense it. As each pill is dispensed, the day of the week is revealed as a reminder that the pill was taken.

This history of the compliance packaging for the Pill is based on prototypes of the first container designed to hold the oral contraceptive, and on a study of the oral contraceptive and advertising in the collections of the Division of Science, Medicine and Society at the Smithsonian's National Museum of American History. The packaging prototypes came to the Smithsonian's collections as the result of a case study of the birth control pill in the Museum's *Science in American Life* exhibit, which opened in April 1994. Dr Celso-Ramón García, who had directed some of the first clinical trials of oral contraceptives, saw the large display of birth control pills in the exhibit and put me in touch with the inventor of the Pill package. The following year, its inventor, David P. Wagner of Geneva, Illinois, donated his prototypes and a small but fascinating collection that includes his design drawings, patent, correspondence, legal documents, and examples of oral contraceptive packages that either did or did not fall within the claims of his patent.⁴ The examination of these packages and advertisements was central to this study.

David P. Wagner invented his dispenser to help his wife remember to take her Pill. Doris Wagner began taking the Pill after their fourth child, Jane, was born on November 14, 1961, and the Wagners decided that their family was complete. The only oral contraceptive on the market in 1961 was Enovid, from G. D. Searle & Co. Prescriptions for Enovid were dispensed as tablets in a small brown bottle. Instructions for taking the Pill seemed straightforward: Doris was to take the first tablet on the fifth day after beginning menstruation, continue with one tablet every day for 20 days, and then stop; she would begin menstruating in two to three days, and on the fifth day of menstruation she was to start another 20-day cycle of tablets. The 20-pill regimen originated in the 1940s, when hormones were first used to treat menstrual problems. It was selected for the oral contraceptive clinical trials so that the hormonally controlled cycle would conform to the average or "normal" 28-day menstrual cycle and would encourage women to view the method as "natural."⁵

David Wagner recalled, "there was a lot of room for error in whether 'the Pill' was actually taken on a given day." He said, "I found that I was just as concerned as Doris was in whether she had taken her pill or not. I was constantly asking her whether she had taken 'the Pill' and this led to some irritation and a marital row or two."⁶ To resolve their frustrations, Wagner listed the days of the week on a piece of paper, put the paper on the dresser in their bedroom, and placed one pill over each day. When Doris removed a pill, the day of the week would be revealed and they could both tell, at a glance, whether she had taken her pill. "This did wonders for our relationship. It lasted for about two or three weeks until something fell and scattered the pills and the paper all over the floor."⁷ Still, he liked the



Figure 2. This 1964 Ortho-Novum advertisement shows the first Dialpak dispenser for the oral contraceptive.

basic idea, but he needed some kind of container to keep the pills oriented to the day of the week, yet prevent them from spilling, even if his wife carried them in her purse. He started "noodling around," and sketched variations of such a pill box.

David Wagner was more than a clever spouse: he was educated to take a technological approach to problem solving. He worked as a product engineer developing new fasteners for Illinois Tool Works, and he already held one patent at the time he invented his dispenser. He recalled:

At this point, I felt I had a pretty good idea, but if I was going to interest anyone in it, I felt I needed several models. So, with just a 1/4" electric drill, a fly cutter to be used in the drill, paper, a saw, a staple, pencil, double-faced transparent tape, several drill bits, a snap fastener that I took off of a child's toy, and several flat, clear sheets of either acrylic or polycarbonate plastic, I fashioned the first pill box for packaging birth control pills. My model is dated 5-15-62. I simulated the pill by sawing thin slices from a wooden dowel.⁸ (see Figure 1)

Wagner applied to patent his invention on July 27, 1962, with the help of a friend who was a patent attorney. Soon afterwards, he paid a visit to the Director of Advertising for G. D. Searle & Co. He said that Searle "felt basically my pill box was a good idea, but at that particular time they were preoccupied with establishing a market and overcoming some adverse

Figure 3. G. D. Searle & Co.'s Compack used a foil blister pack refill that had to be oriented so the black arrow pointed to the day menstrual flow began. The first pill to be taken was marked by a black circle.

publicity.”⁹ He had had the misfortune to approach Searle after it became known that some women taking Enovid had died from blood clots.¹⁰

Wagner had read that Ortho Pharmaceutical also was working on a birth control pill, and he sent them one of his models in the autumn of 1962. A few months later, on February 1, 1963, Ortho placed on the market its first oral contraceptive, Ortho-Novum, in an attractive dispenser called the “Dialpak.” Ortho advertised the Dialpak (*see* Figure 2) prominently, to distinguish its product from the competition. It appeared to Wagner that their design resembled the claims of his patent. As soon as Wagner was issued his patent – on August 4, 1964, a year and a half after the Dialpak appeared on the market – he and his lawyer moved to enforce it. In December 1964 he received his first income from the invention – a cheque from Ortho for \$10,000, in return for signing an agreement not to sue them.¹¹

Wagner made use of Ortho’s success to encourage Searle to re-examine his invention, even before he was awarded his patent. Ortho’s Dialpak had demonstrated the marketing value of his idea and had shown that it could be manufactured “for pennies” as a disposable container. Wagner argued to Searle that his version of the dispenser was easier to understand and operate than the Dialpak, and it would help Searle protect its market share.¹² Searle again rejected his dispenser, on the grounds that they did not feel the need for promotional devices.¹³ Searle’s view of unique packaging as an advertising gimmick is hardly surprising. Drug companies were known in the design community for their “ingrained cautiousness” and the “numbing sameness” of their packaging – a conservatism required, in part, by the need to conform to federal regulations.¹⁴ Yet, when Searle introduced its new, lower dose, Enovid-E in 1964, that, too, came in a special memory dispenser (*see* Figure 3). In 1966, Searle agreed to pay Wagner royalties on the packages for two of their oral contraceptives, Enovid-E and 1 mg Ovulen.¹⁵

Over the years, Wagner received about \$130,000 after legal fees, from his initial \$30 investment in materials. The patent earned \$0.0020–0.0025 per dispenser, according to the legal documents that he signed with Ortho and Searle. He was also paid by Upjohn, the Canadian subsidiary of Organon, Inc., Eli Lilly, and Mead Johnson.¹⁶ Eventually, Wagner tired of fighting for his royalties and sold Ortho Pharmaceutical an undivided half interest in his patent in 1973. It was his last licence for use of the patent.

The origin of the compliance dispenser as an inspiration from the spouse of a patient, rather than from the pharmaceutical company that developed and marketed the product, challenges assumptions about where to look for the source of innovation. It also raises the question of whether pharmaceutical companies ever had any interest in packages designed to

aid patient memory. Surely, such packaging might have appealed to a company's proprietary interests? With a product such as the birth control pill, women who failed to take oral contraceptives correctly and became pregnant were likely to lose confidence in oral contraceptives, and lost confidence could be expected to damage sales. As Searle initially dismissed Wagner's invention, just how unique was his dispenser as a form of pharmaceutical packaging?

Means of reassuring patients that they have taken their medication or reminding them that it's time for another dose have existed for a long time. Nineteenth-century medical spoons in the Smithsonian collections have handles with dial reminders for the convenience of either the patient or the care-giver.¹⁷ A search of the US Patent Office records provided a few other examples, such as a tray patented by Mary C. Mottayaw of Mansfield, Ohio in 1929 that allowed an entire day's medicines to be laid out correctly, and provided a place for setting a timepiece.¹⁸ The Patent Office has surprisingly few examples of similar pill-taking aids until the 1950s, and none are presented as packaging for prescription drugs.

Traditionally, prescription-drug packaging has been designed to protect the integrity of the product while it is in transit from the factory. Pharmacists routinely have dispensed prescription drugs into drab, nearly identical bottles or vials, from larger bottles provided by the drug company. Innovations such as child-proof caps and tamper-proof packages came from consumer-stimulated regulations intended to protect children from accidental poisoning or to prevent malicious tampering with non-prescription drugs, as in the recent Tylenol scare.¹⁹ Unit-dose packages, in which each dose is separately packaged, emerged in the 1960s in hospital pharmacies to control errors made when nurses dispensed medicines to inpatients on the wards.²⁰

The advent of plastics brought new flexibility to package design, but, until the 1960s, few drug companies adopted plastics for prescription-drug packaging. New materials, such as high-density polyethylene, that could replace glass bottles without costly changes in assembly-line filling equipment were adopted primarily because they cut shipping costs, reduced space requirements and did not break in transit. Some more elaborate plastic dispensers for non-prescription drugs are known from the 1950s: Squibb introduced its "Trak-pak" in 1954 to promote aspirin and used it again in 1962 for saccharine, and vitamins such as Squibb's Vigran and cold medications such as Schering's Coricidin were also packaged in dispensers that combined polystyrene and high-density polyethylene. Although none of these designs incorporated memory aids, consumers liked the convenience, and felt that they acquired more for their money when they received a dispenser.²¹ The kind of consumer manipulation that we associate with package designs intended both to advertise and to sell has been conspicuously absent from pharmaceutical products available only by prescription.²²

Aug. 4, 1964

D. P. WAGNER

3,143,207

MEYICATION DISPENSING MEANS

Filed July 27, 1962

3 Sheets-Sheet 2

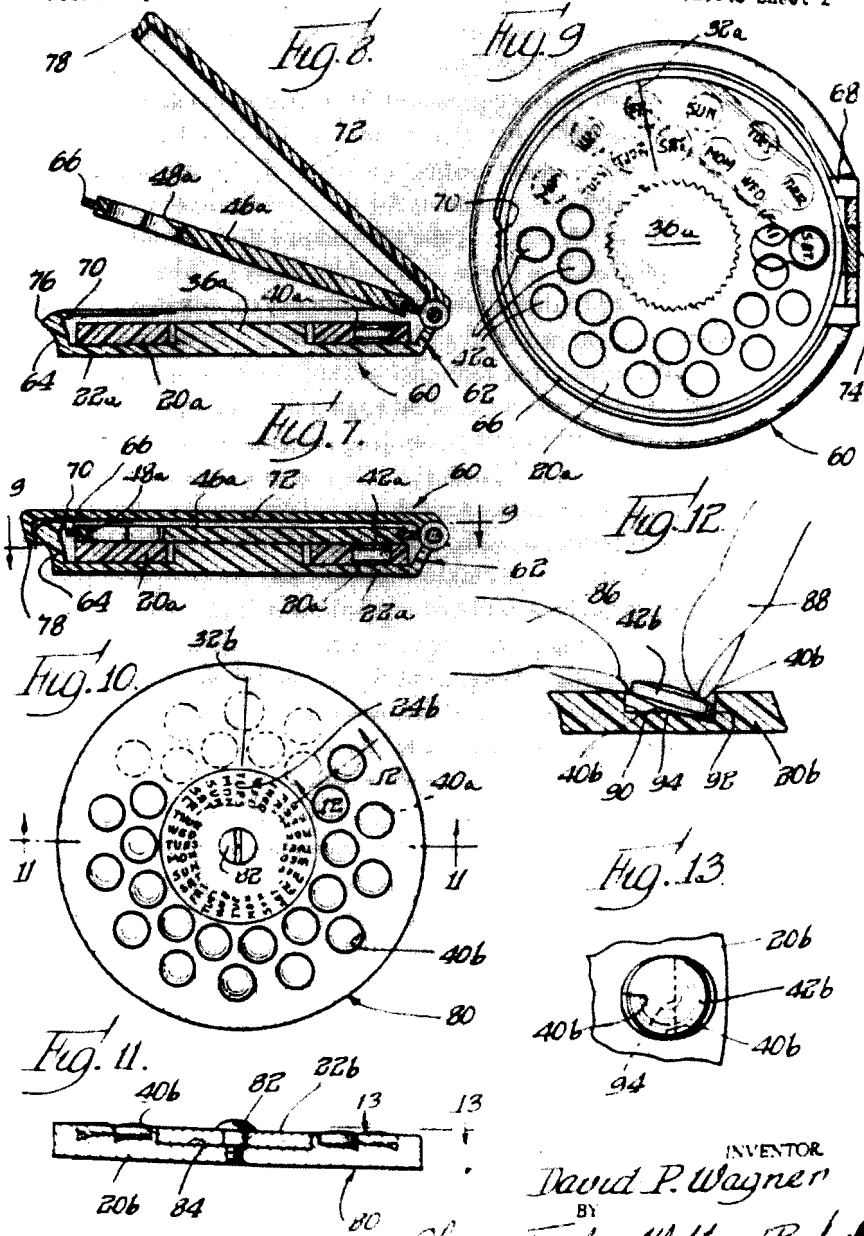
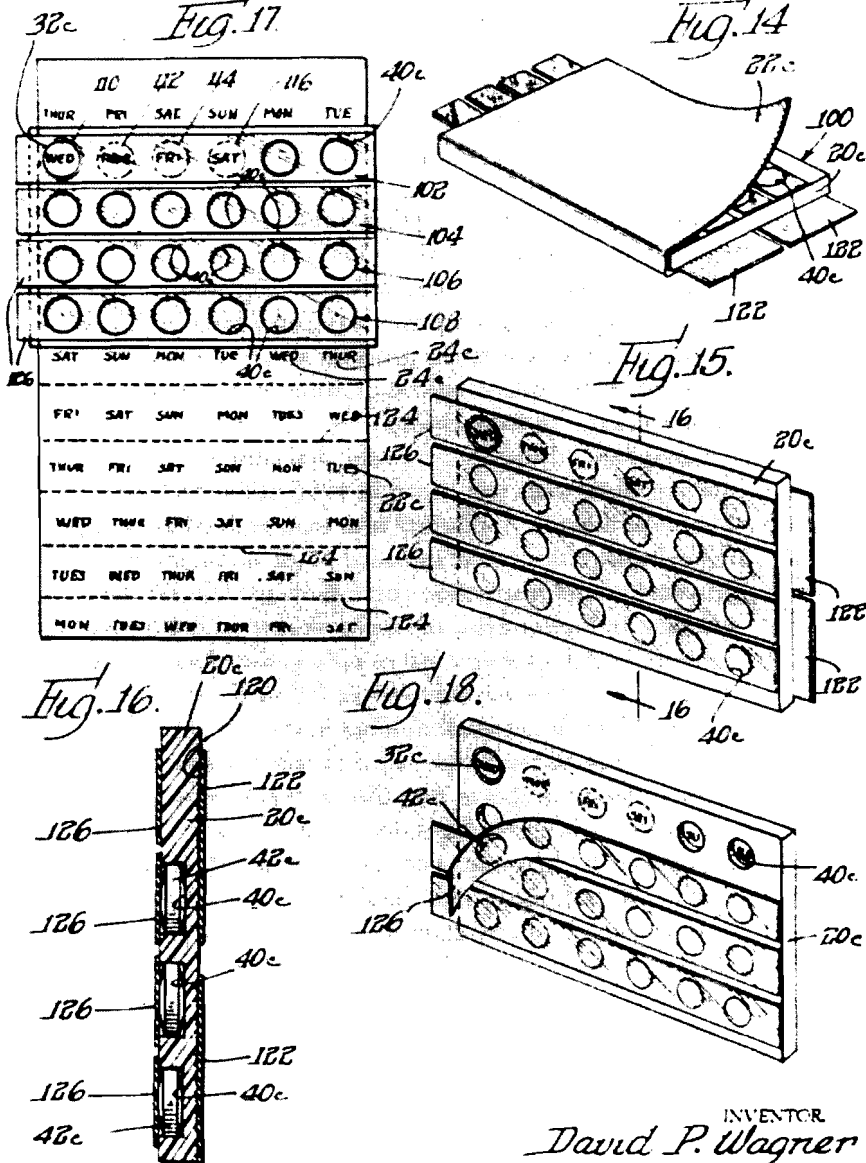

Figure 4. An illustration of the compact version of David P. Wagner's pill dispenser from US Patent # 3,143,207.

MEDICATION DISPENSING MEANS

Filed July 27, 1962

3 Sheets-Sheet 3



INVENTOR
David P. Wagner
 BY
Olson, Treher, Wolter & Bushnell
attys

Figure 5. An illustration of a less costly rectangular version of David P. Wagner's pill dispenser from US Patent # 3,143,207. A sheet of paper is pulled through until the starting day is oriented to the first place on the top row (Fig. 17 Wednesday). The first pill, to be taken on the fifth day, is shown covering Sunday (Fig. 17).

Increased attention to ensuring patient compliance came in the 1950s with new pharmaceutical products that had more complicated medical regimens, particularly the antibiotics and drugs used to treat hypertension. Successful treatment with antibiotics required a patient to take medicine several times a day in order to maintain an effective blood concentration of the drug. Drugs for hypertension created concern, because the patients often had few, if any, symptoms and therefore had less incentive to remember their medication than someone who felt ill. Memory aids such as a combination pocket-watch alarm and pill container, patented in 1960, were devised to assist such patients. The drugs themselves did not come in reminder packages.²³

Attention to patient compliance also emerged in clinical trials during the 1950s. Clinical trials of drugs initially had raised little concern about a patient's ability to follow directions, as most were conducted in monitored environments such as hospitals or prisons. Even in field trials with freely mobile patients, researchers generally determined compliance by monitoring the concentrations of drugs in the blood or urine, rather than devising tactics to aid memory.²⁴

Compliance difficulties with the oral contraceptive emerged first during the large field trials that began in 1956 in Puerto Rico, Los Angeles, Mexico and Haiti. Applicants who were assessed as having difficulty in following directions were excluded at the initial interview. Social workers provided careful instruction and follow-up visits for the women who were enrolled. In Puerto Rico, the social worker visited the participants once a month to deliver a new vial of pills, gather data on any symptoms and determine whether the women had followed the schedule for taking the pills. Nevertheless, a small number in every trial became pregnant because, through "carelessness", they failed to take their medication.²⁵

Lara Marks has shown that clinical trial investigators believed that compliance with procedures depended on a woman's cultural and educational background. They expected wealthier and better-educated women to continue to take the Pill, but believed that those who needed it most – deprived and illiterate women with large families – were less likely to comply with daily pill-taking. For the most part, the women in the trials took the pills as prescribed, but in one troublesome trial in Haiti, more than 20% of participants forgot to take some of the pills. Some women stopped taking them when their husbands were out of town, and others took them all at once. Many of these women could neither read nor count, so the calendars supplied as reminders were of little help. To enhance compliance, the trial team tried giving the women rosary beads, with instructions to move one bead each day when they took a pill. Nevertheless, confusion persisted. Some women wore the beads instead, thinking that the rosary beads alone protected them against pregnancy. Marks notes that "clearly much depended not only on the educational background of women, but also on individual motivation

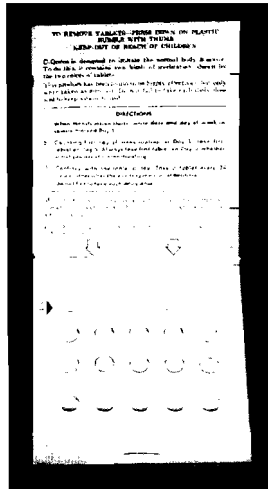

Figure 6. C-Quens, the first sequential oral contraceptive in the USA was distributed by Eli Lilly. It contained two different formulations that had to be taken in sequence. The paper package requested the woman write down the date and day menstruation started to keep track of the regimen.

in the success of following instructions, as well as the skill of the instructor.²⁶

Despite such difficulties, common in the clinical trials, the official reports mention the problems with compliance primarily to explain that pregnancies among the trial patients could not be attributed to technical failure of the oral contraceptive. As long as all pregnancies among trial participants could be dismissed as the result of a deliberate choice to become pregnant or the result of a woman's failure to follow instructions, the contraceptive could be deemed 100% successful. Researchers acknowledged that compliance was a problem, but considered it an issue primarily for international population planners who worked with poor, illiterate women.²⁷ The physicians' conclusions that the method was highly popular and their belief that most women were highly motivated to follow the instructions gave them little reason to encourage G. D. Searle & Company to include memory devices with the Pill.

Once Ortho introduced the Dialpak however, every new birth control pill on the market came with some kind of memory aid. Two primary features determined whether a package fell under the claims of Wagner's patent: (1) the pills were retained in a pattern and (2) they could be adjusted in relation to an element having day-of-the-week identification (see Figures 4 and 5). Wagner found that the pharmaceutical companies were naturally reluctant to pay royalties to "outside" inventors, and either argued strongly that their packages did not infringe his patent, or worked to develop a dispensing device that would not infringe the patent.²⁸ As drug companies introduced new oral contraceptives to the market, they distinguished their products from their competition both through changes in the pill formulation and through changes in the packaging.

Packages that included reminders for the 20-day regimen invariably required some mechanical means of altering the date in relation to the tablet, as the regimen did not fit neatly into the seven-day week. As a result, they invariably fell under the claims of Wagner's patent. The package for Eli Lilly's C-Quens, the first sequential Pill on the American market, introduced in 1965, illustrates the difficulty (see Figure 6). With sequential pills, it was important that the pills be taken in the correct order. C-Quens maintained the 20-day regimen, but gave 15 days of estrogen, followed by five days of an estrogen/progestogen combination, arranging the pills in four rows of five tablets. The package superficially resembled a calendar, but, other than a place to note the date on which the first pill was taken, it offered the taker no help in remembering if she missed a day.²⁹

The desire to avoid conflict with Wagner's patent resulted in design changes that altered the pill-taking regimen. Searle first introduced Ovulen in an adjustable compact identical to the Enovid-E container. The package for Searle's 1-mg oral contraceptive, Ovulen, changed after they agreed to pay royalties to Wagner. Searle reissued the drug as Ovulen-21, in a rectangular compact which added an additional pill to the cycle as a means

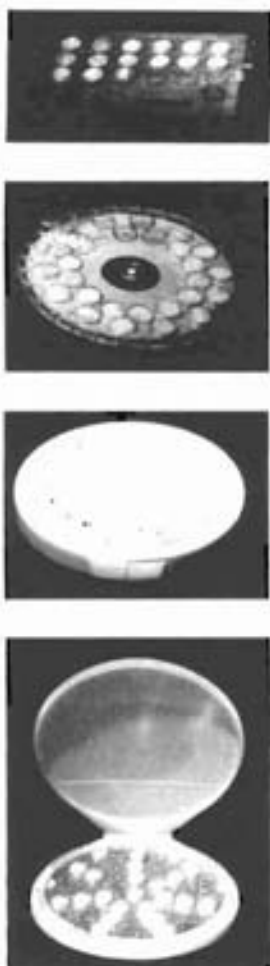

Figure 7. G. D. Searle and Co.'s oral contraceptives are shown with David P. Wagner's prototype (top and second from top). Enovid-E 20 (third) and Ovulen-20 (bottom) had features covered by Wagner's patent.

to avoid adjusting the date – a critical element in Wagner's patent (see Figures 7 and 8). Their advertising copy alerted doctors to the change: "Ovulen-21, works the way a woman thinks by weekdays... not 'cycle days.' Ovulen-21 lets her remember her natural way. Once established, her starting day is always the same day of the week... because it is fixed at three weeks on – one week off and is independent of withdrawal flow."³⁰ The 21-day regimen proved so popular that Ortho brought out their 2-mg pill in a 21-day form, despite retaining their distinctive Dialpak dispenser.³¹

Organon Laboratories in the UK created a 22-tablet regimen for their 2.5-mg oral contraceptive, Lyndiol. They reasoned, as their advertising flyers indicate, that "maximum patient reliability" is ensured when "each course of tablets always begins and ends on the same fixed day of the week... Thus, if the "last" tablet is taken on a Friday evening, then the first tablet from the next pack is taken on the next Friday evening."³² Women throughout the world who used Organon oral contraceptives had their menstrual cycles adjusted to this new regimen. Geigy of Germany also used the 22-tablet regimen for their 2-mg birth control pill, Yermonil.³³

The calendar pack made it evident that, by adding placebos, women could take a pill every day. Oracon, a sequential birth control pill introduced by Mead Johnson in 1965, was available in both a 21-day and a 28-day version.³⁴ The ease of giving instructions for taking the 28-day Pill made that version popular with medical personnel. The simplicity of the 28-day regimen also ensured that the new sequential pills would be taken in the correct order. Theoretically, women could start to take their pills any day of the week, but they especially liked the "Sunday start," as it duplicated the calendar and resulted in "period-free weekends."³⁵

Changes in pill formulation and package design followed the move to the 28-day regimen. The desire that every pill should do something encouraged Parke-Davis to add iron compounds to the seven placebos in 1-mg Norlestrin Fe, as a nutritional supplement to compensate for mineral loss during menstrual bleeding.³⁶ Because women now took a pill every day, many companies abandoned the calendar format, simply adding graphic arrows to a rectangular arrangement of pills in a blister pack to ensure that the user took the pills in the proper sequence.³⁷ In some cases the pill count per package also varied, as illustrated by examples of 35-tablet and 42-tablet packages.³⁸

Package designs for the oral contraceptive were developed that elicited other medically beneficial behavioural changes. One design incorporated a dial to remind a woman to self-examine her breasts for tumours at the optimum time of her cycle, between days seven and twelve.³⁹ Recently, a randomised clinical trial found that even simple prompts resulted in higher rates of self-examination of the breasts. The package design used for the clinical trial simply added the statement, "best time for Breast Self Exam – 7 days after period end" beneath the first row of pills on a calendar pack.⁴⁰



Figure 8. Searle's Enovid-E 21 (top) Ovulen-28 (middle) and Demulen-28 (bottom), all in rectangular compacts, used a 21-day cycle, required no orientation to the day of the week, and were not covered by Wagner's patent.

Aesthetic changes in birth control pill packages reflected societal norms, especially the desire to keep birth control discrete. David Wagner, in his patent, claimed his Pill dispenser would fit into a case "indistinguishable" from a lady's cosmetic "compact," so that it could be carried among her personal effects or in her purse, "without giving a visible clew [sic] as to matters which are of no concern to others."⁴¹ Plastic Pill "compacts" from the 1960s were produced in pastel colours with cameo and floral designs pressed into their surfaces. By the 1980s, the cases were as likely to look like wallets or be designed to resemble credit cards.

Although packaging changes made it easier for women to remember to take the birth control pill, daily pill-taking remained one of the disadvantages of oral contraceptives (see Figure 9). A 1965 study of 5,600 women cited psychological difficulties such as worry about forgetting to take the Pill every morning, and a general dislike of taking a pill every day, among the reasons women switched to other methods of contraception.⁴² For women who missed a Pill, the dispenser reminded them that they might face an unwanted pregnancy, and it seemed to them like "contraceptive roulette," according to *Newsweek*.⁴³ One study gave Pill users psychological tests and identified a range of "pill forgetters' defects" such as the inability to assume responsibility, control impulses or appreciate long-range goals.⁴⁴

Women's "forgetfulness" problem became a common theme of oral-contraceptive advertising in medical journals in the late 1960s, even when the package design was not featured prominently. These advertisements, directed at physicians, repeated the paternalistic view of the doctor-patient relationship common at the time and sometimes presented women as scatter-brained, incompetent and in need of guidance. At the same time, by encouraging doctors to take a more active role in educating the patient, the advertisements hinted that doctors had previously provided poor instructions. Organon depicted a woman who was "newly wed . . . , working still . . . , madly busy . . . , mind awlirl," and urged doctors to "Protect the new patient from her own forgetfulness."⁴⁵ The British Drug Houses of Canada, in promoting their new 28-day sequential oral contraceptive, assured doctors that "Now you can give her a 'pill' that really counts for her."⁴⁶

Gynecology textbooks and consumer manuals offered helpful suggestions for overcoming the problem of "forgetfulness."⁴⁷ For the most part, these seem to be obvious solutions: keep your pills next to your toothbrush, next to the kitchen range, or take them with a particular meal. A Philadelphia women's health clinic recommended that women take their Pill when they heard the theme music for the 11 o'clock news.⁴⁸ Most of their clients listened to the news, and taking the Pill just before bedtime had the double advantage that women who became dizzy or nauseous as a result of taking it slept through the discomfort. In 1993, Organon incorporated this genre of reminder into their "Remember Me Compliance Kit" for Desogen.



Figure 9. This Uncle Sam figurine asks "Have you taken your pill today?" It dates from 1969 protests over the distribution of oral contraceptives through US government-funded health clinics.

The package of birth control pills was presented in a box with a toothbrush, a small bar of soap, a "Remember Me" sticker for the bathroom mirror and the slogan "Brush your teeth, wash your face, take your pill ... once a day, everyday, at the same time."⁴⁹ As an incentive to persuade doctors to prescribe their products, Organon supplied doctors with these complimentary kits to initiate their new oral-contraceptive patients. That so many pharmaceutical company advertisements and gynecology manuals addressed the "forgetfulness" problem, and couples such as the Wagners actively sought methods to keep track of taking the Pill, suggests how complex it was to follow the on-again, off-again 20-tablet cycle, and what an important contribution the compliance package made.

Norplant, representing another example of changes made to a chemical contraceptive to overcome compliance problems, also illustrates the importance of attention to the design and production of medical technologies, and their potential medical and social effects. The Population Council sponsored new research on a chemical contraceptive for international population control that aimed to eliminate altogether the problem of forgetfulness, at the time when pharmaceutical companies were changing package designs to overcome Wagner's patent. This, too, involved an element of packaging – in this case, a unique drug capsule. In 1964, the Population Council's Center for Biomedical Research demonstrated that hormones could be released from silicone rubber capsules implanted in the body. By 1975, clinical trials of a chemical contraceptive in a six-capsule "silastic drug delivery system" implanted under the skin on the inside of a woman's upper arm were under way in several countries. The contraceptive was named Norplant by its manufacturer, Wyeth-Ayerst, and was first approved for use in Finland in 1983. By the mid 1990s, 15 countries had approved it for marketing.⁵⁰ In 1983, levonorgestrel, the pharmaceutical agent used in Norplant, had already been on the market for some years, in the progestin-only mini-pill and in several of the widely used combination Pills.

Clearly, a drug-delivery system represents a different category of compliance packaging than the date-adjustable dispenser. In this case, the dosage form and the container have, in a sense, merged. Previous attempts to extend the effects of drugs had depended on the solubility of a medication or its coating, but the entire product was consumed by the patient. A series of innovations in the 1970s introduced the infusion pump used in intensive care units, transdermal patches, and osmotic systems that both contained and protected a drug while it was released in a controlled way over long periods of time.⁵¹ In the case of Norplant, the silastic tubes filled with powdered levonorgestrel remained under the skin of the woman's arm until the spent container/drug-delivery device was removed by her doctor, five years later.

Dependence on the medical establishment for prescriptions has made oral contraceptives the bane of the women's self-help medical movement ever since the Pill was introduced.⁵² Unlike barrier devices or contraceptive foams and jellies, over which a woman and her partner had complete control, the birth control pill required women to obtain an annual or semi-annual prescription from a physician or a health clinic. Norplant was a boon for women who wanted long-term contraception and found it difficult to remember a daily pill. However, its need to be medically removed made women even more dependent on their medical providers when making decisions about reproduction than did the Pill, which a woman could stop taking whenever she wished.

More seriously, because of its package/drug-delivery system, Norplant could be used to enforce compliance coercively. In the USA, the desire to implement such uses accompanied Norplant from the day it was approved, December 10, 1990.⁵³ Newspaper columnist Ellen Goodman reported that, the first day Norplant was announced, a caller to a radio talk-show proclaimed that every girl should have Norplant stuck in her arm at puberty. The next day, the *Philadelphia Inquirer* published an editorial urging readers to "think about" Norplant as a tool in the fight against black poverty.⁵⁴ A California judge ordered a woman, who was guilty of child abuse, to have Norplant inserted as part of a plea bargain.⁵⁵ Legislatures in 11 states proposed bills (although they passed none of them) to offer financial incentives to women receiving welfare, to encourage them to use Norplant.⁵⁶ Federal Medicaid paid for the insertion of the implants, but states control Medicaid distribution, and in South Dakota, for example, Medicaid would not pay for the removal of Norplant in the absence of a medical reason for doing so.⁵⁷ Such incidents, in the USA and in other countries, have raised alarms about the potential for misuse of Norplant.⁵⁸ For the purposes of this paper, the example is provided in order to emphasise that it was not the hormone in Norplant, but rather its form of *packaging*, that made this contraceptive so easily subject to coercive use.

Auxiliary technologies such as the pharmaceutical package are usually overlooked, but, as the examples of the compliance package and Norplant illustrate, they have both medical and social repercussions. This account argues for the usefulness of studying the artefacts themselves. Examination of the diverse packages for birth control pills in the collections of the National Museum of American History revealed that the number of pills in a package varied from one brand of oral contraceptive to another. Who would have guessed that this difference originated to help women remember to take their pill?

Since the introduction of the Dialpak, compliance packages have become far more common. Drugs with unusual dosage schedules are now likely to

come from the pharmaceutical manufacturer in “unit-of-use” compliance packages designed to let the patient know at a glance when to take the pills each day – packages that also eliminate the need for the doctor or pharmacist to explain complicated schedules. Now, clinical trials can use bottle caps with microelectronic devices that record the time and date when the patient removes the lid to take a pill.⁵⁹ Patient compliance as a health-care issue has gained greater salience in association with increasing health-care costs, aging patients who take multiple medications, and the increase in prominence of chronic diseases associated with lifestyle.

David Wagner started a quiet revolution in package design for prescription drugs, which one would have expected either to come from a pharmaceutical or packaging company, or to have been requested by physicians prescribing oral contraceptives. Rarely are patients or their families considered as sources of innovation and change in medical technologies. Histories of medical technologies, even when they take into consideration the concerns of the patient, portray patients as passive objects to which medical technologies are applied. Patients may request or refuse technical procedures, but the source of change or innovation in a technology invariably is assumed to reside in a dialogue between the doctor, the institution and the inventor or engineer.⁶⁰ The example of the Pill package challenges easy assumptions about sources of change in medical technology and speaks for the importance of considering the whole of a technology when evaluating its medical and social effects.

Notes

1. A note on terminology: Dialpak is a registered trademark of the Ortho Pharmaceutical Company. When capitalised, “Pill” has come, through common parlance, to designate the birth control pill or the oral contraceptive and it will be so used here.
2. See, for example, the cover of *Maclean's*, April 17, 1978, and the jacket cover of Robert W. Kistner, *The Pill: Facts and Fallacies About Today's Oral Contraceptives* (New York, 1968).
3. General histories of the oral contraceptive include James Reed, *From Private Vice to Public Virtue* (New York, 1978), pp. 309–66; Angus McLaren, *A History of Contraception From Antiquity to the Present Day* (London, 1990), pp. 239–67; A. D. G. Gunn, *Oral Contraception in Perspective* (Carnforth, Lancs, UK, 1987); William H. Robertson, *An Illustrated History of Contraception* (Carnforth, Lancs, UK, 1990), pp. 121–38; and Bernard Asbell, *The Pill: A Biography of the Drug that Changed the World* (New York, 1995). Elizabeth Watkins, “On the Pill: How Oral Contraceptives Contributed to Changes in the Practice of Medicine in the Early 1960s,” a paper presented at the American Association for the History of Medicine, April 30, 1994, discusses the Pill and its role in making women more assertive in their medical care. Linda Grant, *Sexing the Millennium* (New York, 1994) examines the pill and the sexual revolution. Lara Marks, “A “Cage” of Ovulating Females: The History of the Early Oral Contraceptive Pill Clinical Trials, 1950–1959,” in *Molecularizing Biology and Medicine, 1910s–1970s*, ed. H. Kamminga and S. De Chadarevian (Amsterdam, 1998) is the first historian to look carefully at the research behind the clinical trials. Gena Corea, *The Hidden Malpractice: How American Medicine Mistreats Women* (New York, 1985) understates the extent of the clinical trials to support her argument. FDA historian Suzanne White-Junod examined the basis for approving the Pill in “FDA's Approval of the Contraceptive Pill,” a paper presented to the Washington Society for the History of Medicine, January 14, 1993.
4. David P. Wagner Collection, Division of Science, Medicine, and Society, National Museum of American History, Smithsonian Institution, Washington, DC.

5. Lara Marks, "'Andromeda Freed from her Chains': Attitudes Towards Women and the Oral Contraceptive Pill, 1950–1970," in *Women and Medicine*, ed. Anne Hardy and Lawrence Conrad (forthcoming). p. 17; Nelly Oudshoorn, *Beyond the Natural Body* (London, 1994), p. 121.
6. David P. Wagner to Patricia Gossel, January 16, 1995, Wagner Collection.
7. Ibid.
8. Ibid.
9. David P. Wagner to John L. Scott, April 19, 1963, Wagner Collection.
10. G. D. Searle & Co., Press Release, August 9, 1962, Science Service Collection, Smithsonian Institution Archives.
11. Wagner to Gossel (n. 6 above); "Agreement between David P. Wagner and Ortho Pharmaceutical Company," November 25, 1964, Wagner Collection. The first patent for a dial dispenser found with Ortho Pharmaceutical Corporation listed as assignee is US Patent 3,557,747 awarded January 26, 1971.
12. Wagner to Scott (n. 9 above).
13. John L. Scott to David P. Wagner, June 14, 1963, Wagner Collection.
14. "Survey of an Industry 1: Packaging Drugs," *Industrial Design* 10, no. 11 (November 1963): 87–91.
15. David P. Wagner, "Covenant Not to Sue G. D. Searle and Company," August 15, 1966, Wagner Collection.
16. Wagner to Gossel (n. 6 above); "Agreement between Wagner and Ortho" (n. 11 above); "Covenant not to Sue Searle" (n. 15 above).
17. Invalid spoon Pat. no. 51748, Cat. no. M-4303, David J. Pearson, donor, Medical Science Collection, National Museum of American History; invalid spoons and dial reminder, Cat. nos. 1994.243.13, 1994.243.14, 1994.243.33, Dorothy Rainwater, donor, Medical Science Collection. With the American enthusiasm for self-dosing, patents for medical spoons flourished in the 1870s through 1890s, see John S. Haller, "Medical Spoons: A Brief Look at Patents of the 1870s and 1880s," *New York State Journal of Medicine* 93 (1993): 183–88. On the use of medical spoons to calibrate the dose, see George Griffenhagen, "Dose: One Spoonful," *Journal of the American Pharmaceutical Association*, 20 (1959): 202–05.
18. US Patent 1,717,060, "Time Chart," issued to Mary C. Mottayaw, Mansfield, Ohio, June 11, 1929.
19. Very little literature exists on the history of prescription-drug packaging. An important exception is William H. Helfand and David L. Cowen, "Evolution of Pharmaceutical Oral Dosage Forms," *Pharmacy in History* 25 (1983): 3–18. See also, "The Search for Tamper-Proof Packaging: The Protection of Product Integrity," A Pictorial Exhibit, The Pharmacist Institute of New Jersey, 1983; and Aimee Rhum, *Tamper Resistant Packaging: What's Ahead?* (Stamford, CN, 1984).
20. Frost and Sullivan, Inc., *Unit Dose Packaged Pharmaceutical Products in Europe* (New York, 1978), pp. 27–28.
21. "Survey of an Industry" (n. 14 above), pp. 87–91; "New Role for Plastics in Drugs," *Modern Packaging* 37, no. 5 (January 1964): 100–03.
22. Thomas Hine, *The Total Package: The Evolution and Secret Meanings of Boxes, Bottles, Cans, and Tubes* (Boston, 1995) and Stanley Sacharow, *The Package as a Marketing Tool* (Radnor, PA, 1982) also attend to the development of package design.
23. US Patent 2,853,182, "Pocket Chronometer and Pill Container," issued to Harry E. Barnett, Chicago, Ill., September 23, 1958.
24. R. B. Haynes et al., *Compliance in Health Care* (Baltimore, 1979); Susan Jay, Iris F. Lirt, and Robert H. Durant, "Compliance with Therapeutic Regimens," *Journal of Adolescent Health Care* 5 (1984): 124–36. See also Daniel A. Hussar, "Patient Compliance," in *Remington's Pharmaceutical Sciences*, 17th ed. (Easton, PA, 1985), pp. 1764–77.
25. Gregory Pincus et al., "Fertility Control with Oral Medication," *American Journal of Obstetrics and Gynecology* 75 (1958): 1343.
26. Marks, "A 'Cage' of Ovulating Females" (n. 3 above), p. 17; Marks, "Andromeda Freed from her Chains" (n. 5 above), pp. 19–20.
27. Edward T. Tyler et al., "An Oral Contraceptive: A Four Year Study of Norethindrone," *Obstetrics and Gynecology* 18 (1961): 367.

28. Wagner to Gossel (n. 6 above).
29. Eli Lilly and Company, "Lilly News," May 5, 1965, Science Service Collection; "C-Quens" oral contraceptive, Cat. no. 82.531.11, Medical Sciences Collection.
30. 1 mg Ovulen advertisement attached to "Covenant Not to Sue Searle" (n. 15 above); "Ovulen-21 Works the Way a Woman Thinks," Searle advertisement, *Virginia Medical Monthly* (August 1968).
31. Ortho trade literature, Syntex Files, Medical Science Collection, National Museum of American History.
32. "In Oral Contraception Lyndiol 2.5 Meets the Case," Organon trade literature, Syntex Files, Medical Science Collection, 1968.
33. Yermonil advertisement, Ciba-Geigy trade literature, Syntex Files, Medical Sciences Collection, July 1975.
34. Oracon oral contraceptive, Cat. no. 81.760.123, Medical Science Collection; Oracon 28 oral contraceptive, Cat. no. 85.475.143, *ibid*.
35. Greg Juhn, *Understanding the Pill: A Consumer's Guide to Oral Contraceptives* (New York, 1994), p. 31.
36. Parke, Davis and Company, News Release, March 7, 1969, Contraceptive Pills – Various Makers File, Science Service Collection.
37. As an example, see Eugynon ED advertisement, Schering Pty Ltd, *Medical Journal of Australia Advertiser* (June 7, 1969): xlv.
38. "Does 'The Pill' Still Need Estrogen?" Exluton trade literature, Organon (Thailand) Ltd, c. 1973, Syntex Files, Medical Science Collection, shows a 35-pill package; Micronor advertisement, *Journal of Obstetrics and Gynaecology of the British Commonwealth* (December 1972): iv, shows a 42-tablet "pushpak."
39. US Patent 5,020,671, "Method and Apparatus for Oprimum Self-examination of Breasts by Users of Birth Control Pills," issued to Raleigh A. Smith, June 4, 1991.
40. Daron G. Ferris et al., "Effectiveness of Breast Self-examination Prompts on Oral Contraceptive Packaging," *The Journal of Family Practice* 42 (1996): 45.
41. US Patent 3,143,207, "Medication Dispensing Means," issued to David P. Wagner, August 4, 1964, col. 1, lines 52–56.
42. Leslie Aldridge Westoff and Charles F. Westoff, *From Now to Zero: Fertility, Contraception and Abortion in America* (Boston, 1971), pp. 109–10.
43. "Birth Control: The Pill and the Church," *Newsweek*, July 6, 1964.
44. Bakker and Dightman, "Psychological Factors in Fertility Control," *Fertility and Sterility* 15 (September/October 1964): 559–67, as reported in Edward E. Wallach and Celso-Ramón García, "Psychodynamic Aspects of Oral Contraception," *Journal of the American Medical Association* 203 (March 11, 1968): 927–30.
45. "Protect the New Patient from Her Own Forgetfulness," Lyndiol advertisement, Organon Laboratories Ltd of England, *Journal of Reproduction and Fertility* (November 1969): iv.
46. "Now You Can Give Her a 'Pill' that Really Counts for Her," Serial 28 advertisement, British Drug Houses (Canada) Ltd, *Canadian Medical Association Journal* 101 (November 29, 1969): 31.
47. Robert A. Hatcher et al., *Contraceptive Technology*, 16th rev. ed. (New York, 1994), p. 273; Juhn (n. 35 above), p. 33.
48. "Birth Control and the 11 P.M. News," *Philadelphia Daily News*, November 9, 1972.
49. Desogen, "Remember Me Compliance Kit," Medical Science Collections.
50. C. Wayne Bardin and Irving Sivin, "Norplant: The First Implantable Contraceptive," in *Contraception: Newer Pharmacological Agents, Devices, and Delivery Systems*, ed. Regine Sitruk-Ware and C. Wayne Bardin (New York, 1992), pp. 23–39; Brij B. Saxena and Mukul Singh, "Delivery of Contraceptive Drug by Subdermal Implants," in *Drug Delivery Devices: Fundamentals and Applications*, ed. Praveen Tyle (New York, 1988), pp. 302–21.
51. Helfand and Cowen, "Evolution of Pharmaceutical Oral Dosage Forms" (n. 19 above).
52. See Sheryl Burt Ruzek, *The Women's Health Movement: Feminist Alternatives to Medical Control* (New York, 1978); and The Boston Women's Health Book Collective, *Our Bodies, Ourselves* (New York, 1973).
53. John A. Robertson, *Children of Choice: Freedom and the New Reproductive Technologies* (Princeton, NJ, 1994), pp. 69–93, examines the social, ethical and legal consequences of Norplant.

54. Ellen Goodman, "The Politics of Norplant," *Washington Post*, February 19, 1991, p. A17.
55. Anita Hardon, "Norplant: Conflicting Views on its Safety and Acceptability," in *Issues in Reproductive Technology, An Anthology I*, ed. Helen Bequaert Holmes (New York, 1992), p. 27.
56. Tim Larimer, "Arming Girls Against Pregnancy," *USA Weekend*, February 26–28, 1993, p. 22.
57. Alexander Cockburn, "Norplant and the Social Cleansers, Part II," *The Nation*, July 25/August 1, 1994, p. 116.
58. Anita Hardon (n. 55 above), pp. 11–30.
59. Dorothy L. Smith, "Compliance Packaging: A Patient Education Tool," *American Pharmacy* NS 29 (February 1989): 42–53.
60. Joel D. Howell's revealing account of the use of medical technologies in hospitals, *Technology in the Hospital: Transforming Patient Care in the Early Twentieth Century* (Baltimore, 1995), stresses the importance of the doctor–patient relationship in affecting the choice of technologies.